

Features:

- 8 Probe Inputs Standard – Expandable to 24
- Interchangeable Microwave Probes



The Holaday HI-2651 is a revolutionary system designed to minimize the time- and labor-intensive processes involved in microwave oven leakage measurement. Its sophisticated system design and application provides oven manufacturers considerable total cost savings against more manual testing methods.

The HI-2651 ATE System interfaces with your existing Microwave Oven Production System to allow for extremely fast data collection, measurement and fault analysis of newly manufactured microwave ovens.

System Diagram

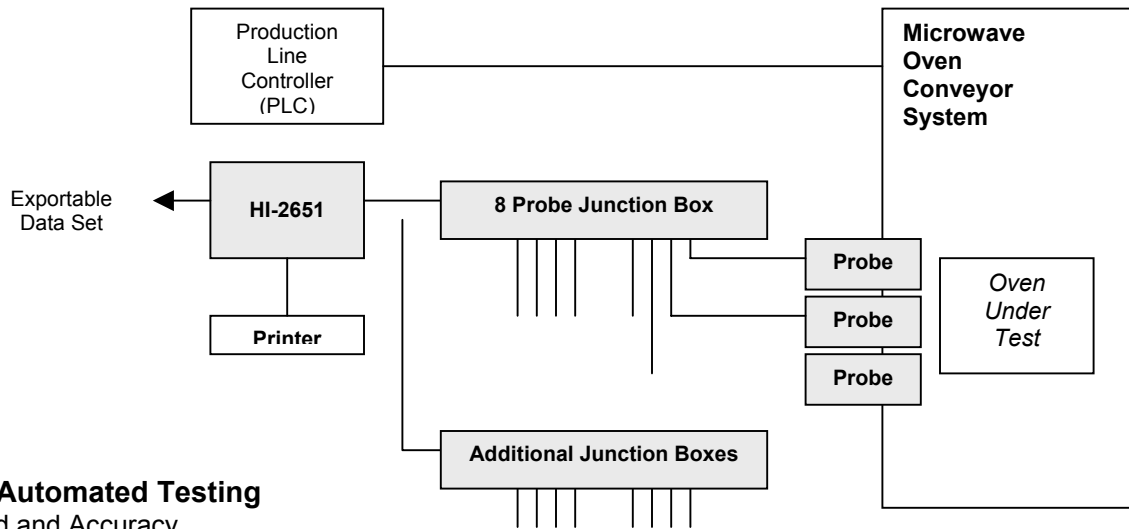

Benefits of Automated Testing

- Speed and Accuracy
- Labor Reduction
- Cycle Time Reduction
- Total Cost Savings
- Consistent Test Procedures
- Improved Record-Keeping

Sample Graphical Scan Screen



Typical Conveyor System and Probes



Specifications

HI-2651 Control Module

- 2 RS232 Serial Ports
- 1 Parallel Printer Port
- 1 Conveyor Interface
- Front Panel Membrane Keyboard
- 14" SVGA Color Monitor
- Industrial Cabinetry (19"W Rack-Mount, 20"D, 14"H)
- Standard PC Keyboard Port

Probes

- Calibrated at 2450MHz
- Absolute Accuracy at Calibration Point $\pm 0.15\text{dB}$
- Maximum Power Limit 2 W/cm^2
- 12" Probe Length
- 12' Probe Cable Length

Probe Junction Box

- 20' Cable Length to HI-2651
- Additional Junction Box Expansion Kit (Part Number 491108)

Holiday has designed and installed automated microwave oven test systems to meet governmental performance standards requirements throughout the world. Let us help you achieve the benefits of automated testing!